

1489-M Circuit Breakers

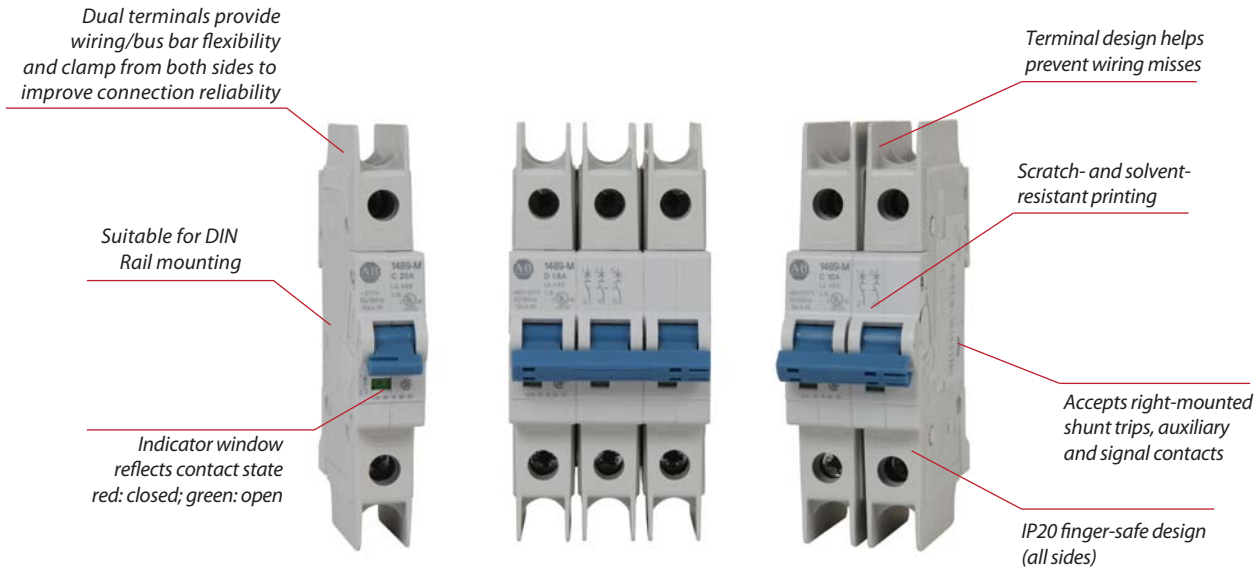

Bulletin 1489-M thermal-magnetic Circuit Breakers are approved for branch circuit protection in the United States and Canada, and are certified as Miniature Circuit Breakers for IEC applications.

These branch protectors are compatible with many accessories to meet diverse application needs, including UL 508 Listed bus bars for convenience in panel assembly, auxiliary contacts, signal contacts and shunt trips for versatility, and lockout attachments for safety during maintenance.

Features

- Current limiting
- Fast breaking time
- High rated voltage
- Dual terminals provide a more secure connection of up to four wires, or two wires and a bus bar
- Superior shock and vibration resistance to help prevent nuisance tripping
- Terminal design helps prevent wiring misses by directing wires into the terminal openings, even while tightening
- Reversible line and load connections
- Single and multi-pole toggle mount lock out attachments available for Lockout/Tagout (LOTO)
- RoHS compliant and fully recyclable device
- Suitable for extreme ambient conditions

1489-M Circuit Breakers

Rated Voltage	UL/CSA: Max. 480Y/277V AC IEC: U_g 230/400V AC
Interrupting Capacity	UL/CSA: 10 kA IEC: 15 kA
Current Ratings	0.5...63 A
Poles	1, 2, 3
Trip Curves	C, D
Standards Compliance	UL 489 CSA C22.2 No. 5.1 EN 60947-2 GB 14048.2
Certifications	UL Listed, File No. E197878 CSA Certified, File No. 259391 CE Marked VDE Certified CCC Certified RoHS Compliant

Catalog Number Explanation

Note: Examples given in this section are for reference purposes. This basic explanation should not be used for product selection; some combinations may not produce a valid catalog number.

1489 - **M** **1** **C** **005**
a *b* *c* *d*

a

Voltage Type	
Code	Description
M	AC Circuit Breaker

b

Poles	
Code	Description
1	1-Pole
2	2-Pole
3	3-Pole

c



Trip Curve	
Code	Trip Curve
C	Trip Curve C
D	Trip Curve D

d

Rated Current (I_n)	
Code	Current [A]
005	0.5
010	1
016	1.6
020	2
030	3
040	4
050	5
060	6
070	7
080	8
100	10
130	13
150	15
160	16
200	20
250	25
300	30
320	32
350	35
400	40
500	50
600	60
630	63

Product Selection

1-Pole Circuit Breakers

Photo/Wiring Diagram	UL/CSA Max. Voltage	IEC/EN Max. Voltage	Continuous Current Rating (I_n) [A]	Trip Curve C Inductive 5...10 I_n Cat. No.	Trip Curve D Highly Inductive 10...20 I_n Cat. No.
  1-pole	277V AC, 48V DC	230V AC	0.5	1489-M1C005	1489-M1D005
			1	1489-M1C010	1489-M1D010
			1.6	1489-M1C016	1489-M1D016
			2	1489-M1C020	1489-M1D020
			3	1489-M1C030	1489-M1D030
			4	1489-M1C040	1489-M1D040
			5	1489-M1C050	1489-M1D050
			6	1489-M1C060	1489-M1D060
			7	1489-M1C070	1489-M1D070
			8	1489-M1C080	1489-M1D080
			10	1489-M1C100	1489-M1D100
			13	1489-M1C130	1489-M1D130
			15	1489-M1C150	1489-M1D150
			16	1489-M1C160	1489-M1D160
			20	1489-M1C200	1489-M1D200
			25	1489-M1C250	1489-M1D250
			30	1489-M1C300	1489-M1D300
			32	1489-M1C320	1489-M1D320
			35	1489-M1C350	1489-M1D350
		C Curve: 277V AC, 48V DC D Curve: 240V AC, 48V DC		40	1489-M1C400
	240V AC, 48V DC		50	1489-M1C500	1489-M1D500
			60	1489-M1C600	1489-M1D600
			63	1489-M1C630	1489-M1D630

Product Selection

2-Pole Circuit Breakers

Photo/Wiring Diagram	UL/CSA Max. Voltage	IEC/EN Max. Voltage	Continuous Current Rating (I_n) [A]	Trip Curve C Inductive 5...10 I_n Cat. No.	Trip Curve D Highly Inductive 10...20 I_n Cat. No.
	480Y/277V AC, 96V DC	400V AC	0.5	1489-M2C005	1489-M2D005
			1	1489-M2C010	1489-M2D010
			1.6	1489-M2C016	1489-M2D016
			2	1489-M2C020	1489-M2D020
			3	1489-M2C030	1489-M2D030
			4	1489-M2C040	1489-M2D040
			5	1489-M2C050	1489-M2D050
			6	1489-M2C060	1489-M2D060
			7	1489-M2C070	1489-M2D070
			8	1489-M2C080	1489-M2D080
			10	1489-M2C100	1489-M2D100
			13	1489-M2C130	1489-M2D130
			15	1489-M2C150	1489-M2D150
			16	1489-M2C160	1489-M2D160
			20	1489-M2C200	1489-M2D200
			25	1489-M2C250	1489-M2D250
			30	1489-M2C300	1489-M2D300
			32	1489-M2C320	1489-M2D320
			35	1489-M2C350	1489-M2D350
		C Curve: 480Y/277V AC, 96V DC D Curve: 240V AC, 96V DC		40	1489-M2C400
	240V AC, 96V DC		50	1489-M2C500	1489-M2D500
			60	1489-M2C600	1489-M2D600
			63	1489-M2C630	1489-M2D630

Product Selection

3-Pole Circuit Breakers

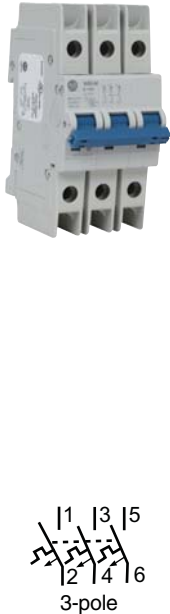
Photo/Wiring Diagram	UL/CSA Max. Voltage	IEC/EN Max. Voltage	Continuous Current Rating (I_n) [A]	Trip Curve C Inductive 5...10 I_n Cat. No.	Trip Curve D Highly Inductive 10...20 I_n Cat. No.
	480Y/277V AC	400V AC	0.5	1489-M3C005	1489-M3D005
			1	1489-M3C010	1489-M3D010
			1.6	1489-M3C016	1489-M3D016
			2	1489-M3C020	1489-M3D020
			3	1489-M3C030	1489-M3D030
			4	1489-M3C040	1489-M3D040
			5	1489-M3C050	1489-M3D050
			6	1489-M3C060	1489-M3D060
			7	1489-M3C070	1489-M3D070
			8	1489-M3C080	1489-M3D080
			10	1489-M3C100	1489-M3D100
			13	1489-M3C130	1489-M3D130
			15	1489-M3C150	1489-M3D150
			16	1489-M3C160	1489-M3D160
			20	1489-M3C200	1489-M3D200
			25	1489-M3C250	1489-M3D250
			30	1489-M3C300	1489-M3D300
			32	1489-M3C320	1489-M3D320
			35	1489-M3C350	1489-M3D350
		C Curve: 480Y/277V AC D Curve: 240V AC		40	1489-M3C400
	240V AC		50	1489-M3C500	1489-M3D500
			60	1489-M3C600	1489-M3D600
			63	1489-M3C630	1489-M3D630

Specifications

Electrical Ratings					
Poles	1, 2, 3				
Tripping characteristics	C, D				
Rated current (I_n)	0.5...63 A				
Rated frequency [f]	50/60 Hz				
Rated insulation voltage U_i per IEC/EN 60664-1	250V AC (phase to ground) 440V AC (phase to phase)				
Overvoltage category	III				
Pollution degree	3				
Data per UL/CSA					
Rated voltage	AC	1-pole	C Curve	0.5...40 A	277V AC
				50...63 A	240V AC
		D Curve		0.5...35 A	277V AC
				40...63 A	240V AC
	2-, 3-pole	C Curve		0.5...40 A	480Y/277V AC
				50...63 A	240V AC
		D Curve		0.5...35 A	480Y/277V AC
				40...63 A	240V AC
DC	1-pole			48V DC	
	2-pole			96V DC (2-pole in series)	
Rated interrupting capacity per UL 489		10 kA			
Reference temperature for tripping characteristics		40 °C			
Electrical endurance		6,000 operations (AC and DC); 1 cycle (1s - ON, 9s - OFF)			
Data per IEC/EN 60947-2					
Rated operational voltage (U_e)	1-pole		230V AC		
	2-, 3-pole		400 V AC		
Highest supply or utilization voltage (U_{max})	AC	1-pole	253/440V AC		
		2-, 3-pole	440V AC		
	DC ★	1-pole	48V DC		
		2-pole	96V DC		
Min. operating voltage		12V AC, 12V DC			
Rated ultimate short-circuit breaking capacity (I_{CU})		15 kA			
Rated service short-circuit breaking capacity (I_{CS})		≤40 A: 11.25 kA >40 A: 7.5 kA			
Rated impulse withstand voltage U_{imp} . (1.2/50μs)		4 kV (test voltage 6.2kV at sea level, 5kV at 2,000m)			
Dielectric test voltage		2 kV (50/60Hz, 1 min.)			
Reference temperature for tripping characteristics		30 °C			
Electrical endurance		$I_n < 30A$:20,000 ops.(AC) $I_n \geq 30A$:10,000 ops. (AC) 1,000 ops. (DC)			
1 cycle (2s - ON, 13s - OFF, $I_n \leq 32A$),					
1 cycle (2s - ON, 28s - OFF, $I_n > 32A$)					

★ Self-declared IEC DC ratings.

Mechanical Data		
Housing	Insulation group II, RAL 7035	
Indicator window	red ON/green OFF	
Protection degree per EN 60529	IP20, IP40 in enclosure with cover	
Mechanical endurance	20,000 operations	
Shock resistance per IEC/EN 60068-2-27	25 g - 2 shocks - 13 ms	
Vibration resistance per IEC/EN 60068-2-6	5g - 20 cycles at 5...150...5 Hz with load 0.8 In	
Environmental		
Environmental conditions (damp heat) per IEC/EN 60068-2-30	28 cycles with 55°C/90-96% and 25°C/95-100%	
Ambient temperature Δ	-25...+55 °C	
Storage temperature	-40...+70 °C	
Installation		
Terminal	Dual terminal	
Cross-section of wire ◆ – solid, stranded (front/back terminal slot)	35/35 mm ²	
	18...4/18...10 AWG	
Cross-section of wire – flexible (front/back terminal slot)	25/10 mm ²	
Multi-wire rating per UL, CSA	1 wire, 18...4 AWG	
	2-4 wires‡, 18...10 AWG	
Cross-section of bus bars (back terminal slot)	10 mm ²	
Tightening torque	IEC	2.8 N•m
	UL/CSA	AWG 18...16: 13.3 in•lb, AWG 14...10: 17.7 in•lb, AWG 8...4: 39.8 in•lb
Screwdriver	No. 2 Pozidrive	
Mounting	DIN Rail (EN 60715, 35 mm) with fast clip	
Mounting position	Any	
Supply	Optional	
Approximate Dimensions and Weight		
Pole dimensions (H x D x W)	111 x 69 x 17.5 mm (4.37 x 2.72 x .69")	
Pole weight	125 g (4.4 oz.)	
Combination with Auxiliary Elements		
Auxiliary contact	Yes	
Signal contact	Yes	
Shunt trip	Yes	

◆ 35 mm self-declared, not included in IEC/EN approval.

Δ Refer to the ambient temperature derating tables.

‡ Wires must be of like size and stranding. Up to two wires per terminal slot.

Power Loss Due to Current

Rated Current [A]	Power Loss Per Pole [W]	Rated Current [A]	Power Loss Per Pole [W]
0.5	1.4	15	2.4
1	1.4	16	2.5
1.6	1.8	20	2.5
2	1.8	25	3.2
3	1.6	30	3.5
4	1.8	32	3.7
5	1.9	35	4.1
6	2.0	40	4.5
7	1.1	50	4.5
8	1.5	60	4.9
10	2.1	63	5.4
13	2.3	—	—

Zero-stack Derating

The installation of several miniature circuit breaker side by side with rated current on all poles requires a correction factor to the rated current (not required if spacers are used).

No. of Adjacent Devices	Factor
1	1
2,3	0.9
4,5	0.8
≥ 6	0.75

Approximate Dimensions

Note: Dimensions are shown in millimeters (inches). Dimensions are not intended for manufacturing purposes.

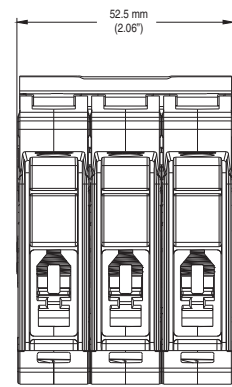
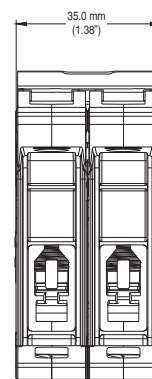
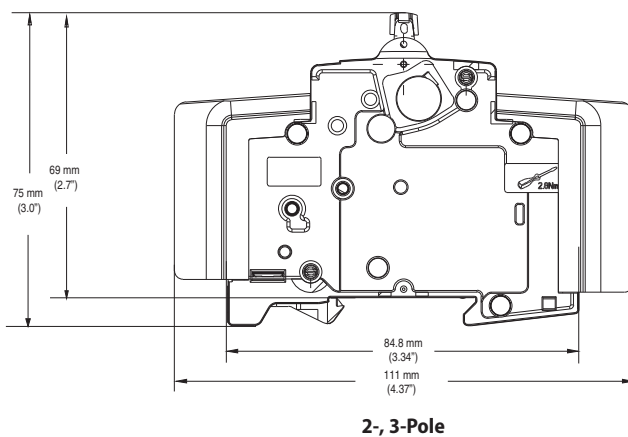
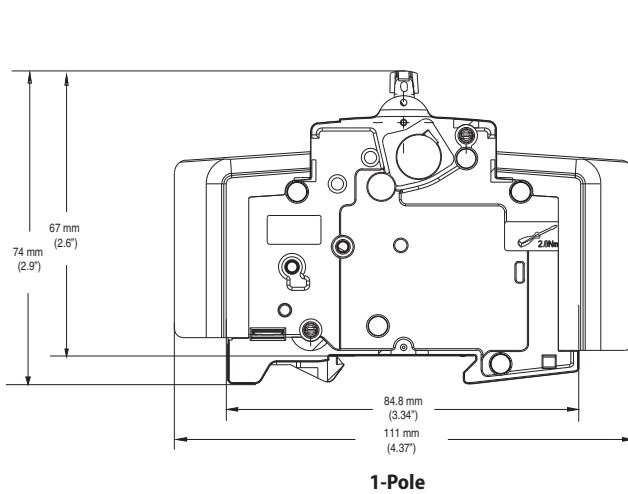

Application Information

Circuit Voltage

The Bulletin 1489-M circuit breakers are rated by voltage class. Applications should not exceed the listed voltage and current range.

Circuit Frequency

The Bulletin 1489-M circuit breakers may be applied to frequencies of 50 Hz and 60 Hz without derating. For applications above 60 Hz, contact Rockwell Automation with specific application information for the derating of the circuit breakers.

Available Short Circuit Current

The Bulletin 1489-M circuit breakers should only be applied in those applications in which the available short-circuit (or fault) current is less than or equal to 10 kA (US/Canada) and 15 kA (IEC).

Tripping Characteristics

The trip curve characteristics are shown on the following pages. The trip bands shown for each breaker represent current tripping limits for a circuit breaker and are within the limits established by UL.

The standard tripping characteristic for Bulletin 1489-M is Type C. Type C has a magnetic trip activated at 5-10 times the rated current of the circuit breaker. The reference temperature for the thermal tripping characteristics is 30 °C. The Type C characteristic will suit most applications.

In rare occurrences when the Type C characteristic does not fully meet the application, Type D magnetic trip characteristic is available, allowing for transients approximately twice as high as the standard Type C.

For a specific current at 30 °C, a circuit breaker will open ("clear the circuit") automatically at some total time that will be within the minimum and maximum time shown on the curves. For example, a one-pole, 15 A, Bulletin 1489-M circuit breaker trips in not less than 1 s and not more than 200 s on a 30 A current. Because the UL standard defines this time spread, users should not specify exact tripping time. The lower current portion of the curves (upper left) depicts the time to trip due to thermal action and reflect overload protection of the wire and connect load. The higher current portion of the curves (lower right) depicts the trip due to magnetic action of the circuit breaker and reflects protection due to short circuit level currents.

Application Considerations

The following is a discussion of application considerations related to North American applications. When applying product to IEC regional requirements, follow IEC practices and guidelines.

The selection of a specific ampere rating for a specific application is dependent on the type of load and duty cycle and is governed by the National Electrical Code (Canadian Electrical Code) and UL/CSA. In general, the codes require that overcurrent protection is at the current supply and at points where wire sizes are reduced. In addition, the codes state that conductors be protected according to their current carrying capacity. There are specific situations that require application consideration, such as motor circuit, and guidelines for the selection for transformer protection.

The Bulletin 1489-M circuit breakers are "non-100% rated" as defined by UL 489, para 7.1.4.2. As such, the circuit breaker's rating should be loaded to no more than 80% if used with continuous loads.

Line and load may be reversed. The Bulletin 1489-M circuit breaker may be bottom fed.

Branch Circuits

Bulletin 1489-M circuit breakers may be used to protect branch circuits. A branch circuit is the wiring portion of a system extending beyond the final overcurrent device protecting the circuit. Guidelines established in NEC, CEC, UL, and CSA should be used to determine the specific device. For example:

Motor Branch Circuit

Bulletin 1489-M circuit breakers are not horsepower rated because they are able to safely interrupt currents far in excess of the locked rotor value for a selected motor. This ability is recognized in the codes and standards and is also established by the UL and CSA tests described in UL 489 and CSA C22.2 No. 5 standards.

The size of a Bulletin 1489-M circuit breaker should be determined following the guidelines for an Inverse Time Circuit Breaker.

References: NEC 430.51 and UL 489. Also see CEC and appropriate Canadian Standards.

Transformer Protection

Bulletin 1489-M circuit breakers may be used for transformer protection following the guidelines established.

References: NEC 450 and UL 489. Also see CEC and appropriate Canadian Standards.

Heater Load, Lighting, and Other Load Protection
Bulletin 1489-M circuit breakers may be used for protection of heater loads, lighting loads, and other loads following the guidelines established.

References: NEC Article 31 and UL 508A. Also see CEC and appropriate Canadian Standards.

SWD Rating

The Bulletin 1489-M breakers (0.5 ... 20 A) are rated as Switch Duty (SWD) and as such may be applied to switch fluorescent lighting loads up to their current and voltage maximum.

Coordinated Overcurrent Protection

Where an orderly shutdown is required to minimize the hazards to personnel and equipment, a system of coordination based upon the faulted or overloaded circuit is isolated by selective operation of only the overcurrent protective device closest to the overcurrent condition. The user should select devices that meet this requirement.

References: NEC 240.12. Also see CEC.

HACR Rating

Bulletin 1489-M Circuit Breakers are rated as Heating, Air Conditioning and Refrigeration circuit breakers as defined by UL 489, paragraph 6.7 and may be used in this type of application.

Current Limiting

Bulletin 1489-M Circuit Breakers are rated as current limiting circuit breakers as defined by UL 489, paragraph 8.6.

The Bulletin 1489-M line features the ability to achieve short circuit interruptions far more effectively than conventional breakers. In conventional circuit breakers, the short circuit interruption time required is approximately one or two half cycles of an AC sine wave. When the contacts open, the resulting arc continues to burn until the current level passes through zero. The arc may re-ignite because of the insufficient width of the contact gap. The current that flows until the arc is extinguished produces a heating effect proportional to the I^2t value (let-through-energy) of the fault current.

The Bulletin 1489-M device is designed to substantially reduce the amount of let-through-current and the resulting let-through-energy that can damage protected components. The Bulletin 1489-M has the ability to interrupt short circuit current within the first half cycle of the fault. Limiting let-through current and energy will protect against the harmful effects of overcurrent and is focused primarily on avoiding excessive heat and mechanical damage.

Both of these factors are proportional to the square of the current. Thermal energy is proportional to the square of the RMS value and magnetic forces are proportional to the square of the peak value. The most effective way to provide protection is to substantially limit let-through-energy. This provides the following advantages:

- Far less damage at the location of the short circuit.
- Fast electric separation of a faulty unit from the system, especially power supplies connected in parallel that are switched off when the voltage of the power bus drops below a certain level.
- Far less wear on the miniature circuit breaker itself. This means more safe interruptions.
- Better protection of all components in the short circuit path.
- Far wider range of selective action when used with an upstream protective device. (No nuisance shut downs from feeder line interruptions, causing a blackout in all connected branches.)

Ambient Temperature Derating

The Bulletin 1489-M circuit breakers are rated in RMS amperes at a 40 °C (104 °F) ambient temperature per UL 489/CSA C22.2 No. 5. This temperature is used as the ambient temperature external to an industrial enclosure. If a circuit breaker is applied in a temperature that exceeds the 40 °C (104 °F) ambient rating, then the circuit breaker should be derated using the table below. For IEC 60947-2 standard, the products carry an ambient rating of 30 °C. Follow standard IEC application considerations for temperature rating in different ambient temperatures.

Note: Application below 0° C is for non-condensing atmosphere. Care should be taken for applications below 0 °C. These devices are not certified to operate correctly in the presence of ice.

Bulletin 1489-M
Temperature Derating, UL
Reference temperature = 40 °C

Current Rating (A)	Ambient temperature (°C)									
	-25	-20	-10	0	10	20	30	40	50	55
0.5	0.6	0.6	0.6	0.6	0.6	0.5	0.5	0.5	0.5	0.5
1	1.2	1.2	1.2	1.1	1.1	1.1	1.0	1	1.0	0.9
1.6	2.0	2.0	1.9	1.8	1.8	1.7	1.7	1.6	1.5	1.5
2	2.5	2.4	2.4	2.3	2.2	2.1	2.1	2	1.9	1.9
3	3.7	3.7	3.6	3.4	3.3	3.2	3.1	3	2.9	2.8
4	5.0	4.9	4.7	4.6	4.4	4.3	4.1	4	3.9	3.8
5	6.2	6.1	5.9	5.7	5.6	5.4	5.2	5	4.8	4.7
6	7.4	7.3	7.1	6.9	6.7	6.4	6.2	6	5.8	5.7
7	8.7	8.6	8.3	8.0	7.8	7.5	7.3	7	6.7	6.6
8	9.9	9.8	9.5	9.2	8.9	8.6	8.3	8	7.7	7.6
10	12.4	12.2	11.9	11.5	11.1	10.7	10.4	10	9.6	9.4
13	16.1	15.9	15.4	14.9	14.4	14.0	13.5	13	12.5	12.3
15	18.6	18.3	17.8	17.2	16.7	16.1	15.6	15	14.4	14.2
16	19.8	19.6	19.0	18.4	17.8	17.2	16.6	16	15.4	15.1
20	24.8	24.4	23.7	23.0	22.2	21.5	20.7	20	19.3	18.9
25	31.0	30.6	29.6	28.7	27.8	26.9	25.9	25	24.1	23.6
30	37.2	36.7	35.6	34.4	33.3	32.2	31.1	30	28.9	28.3
32	39.7	39.1	37.9	36.7	35.6	34.4	33.2	32	30.8	30.2
35	43.4	42.8	41.5	40.2	38.9	37.6	36.3	35	33.7	33.1
40	49.6	48.9	47.4	45.9	44.4	43.0	41.5	40	38.5	37.8
50	62.0	61.1	59.3	57.4	55.6	53.7	51.9	50	48.2	47.2
60	74.4	73.3	71.1	68.9	66.7	64.4	62.2	60	57.8	56.7
63	78.2	77.0	74.7	72.3	70.0	67.7	65.3	63	60.7	59.5

Bulletin 1489-M
Temperature Derating, IEC
Reference temperature = 30 °C

Current Rating (A)	Ambient temperature (°C)										
	-25	-20	-10	0	10	20	30	40	50	55	
0.5	0.6	0.6	0.6	0.6	0.5	0.5	0.5	0.5	0.5	0.5	
1	1.2	1.2	1.1	1.1	1.1	1.0	1	1.0	0.9	0.9	
1.6	1.9	1.9	1.8	1.8	1.7	1.7	1.6	1.5	1.5	1.5	
2	2.4	2.4	2.3	2.2	2.1	2.1	2	1.9	1.9	1.8	
3	3.6	3.6	3.4	3.3	3.2	3.1	3	2.9	2.8	2.7	
4	4.8	4.7	4.6	4.4	4.3	4.1	4	3.9	3.7	3.6	
5	6.0	5.9	5.7	5.6	5.4	5.2	5	4.8	4.6	4.5	
6	7.2	7.1	6.9	6.7	6.4	6.2	6	5.8	5.6	5.4	
7	8.4	8.3	8.0	7.8	7.5	7.3	7	6.7	6.5	6.4	
8	9.6	9.5	9.2	8.9	8.6	8.3	8	7.7	7.4	7.3	
10	12.0	11.9	11.5	11.1	10.7	10.4	10	9.6	9.3	9.1	
13	15.6	15.4	14.9	14.4	14.0	13.5	13	12.5	12.0	11.8	
15	18.1	17.8	17.2	16.7	16.1	15.6	15	14.4	13.9	13.6	
16	19.3	19.0	18.4	17.8	17.2	16.6	16	15.4	14.8	14.5	
20	24.1	23.7	23.0	22.2	21.5	20.7	20	19.3	18.5	18.2	
25	30.1	29.6	28.7	27.8	26.9	25.9	25	24.1	23.2	22.7	
30	36.1	35.6	34.4	33.3	32.2	31.1	30	28.9	27.8	27.2	
32	38.5	37.9	36.7	35.6	34.4	33.2	32	30.8	29.6	29.0	
35	42.1	41.5	40.2	38.9	37.6	36.3	35	33.7	32.4	31.8	
40	48.1	47.4	45.9	44.4	43.0	41.5	40	38.5	37.0	36.3	
50	60.2	59.3	57.4	55.6	53.7	51.9	50	48.2	46.3	45.4	
60	72.2	71.1	68.9	66.7	64.4	62.2	60	57.8	55.6	54.5	
63	75.8	74.7	72.3	70.0	67.7	65.3	63	60.7	58.3	57.2	

Tripping Characteristics

C Curve

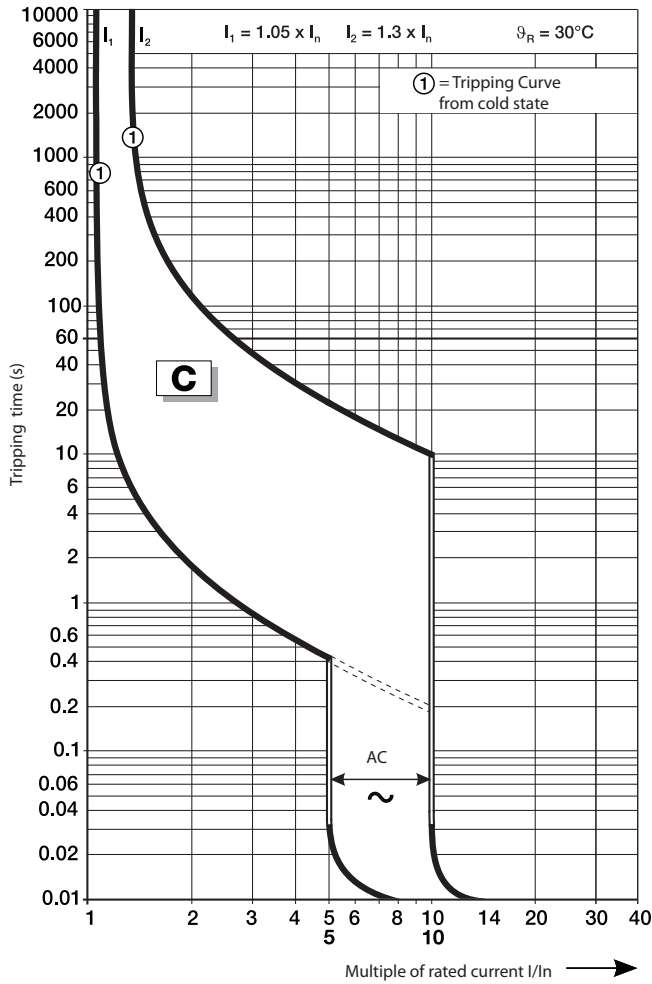



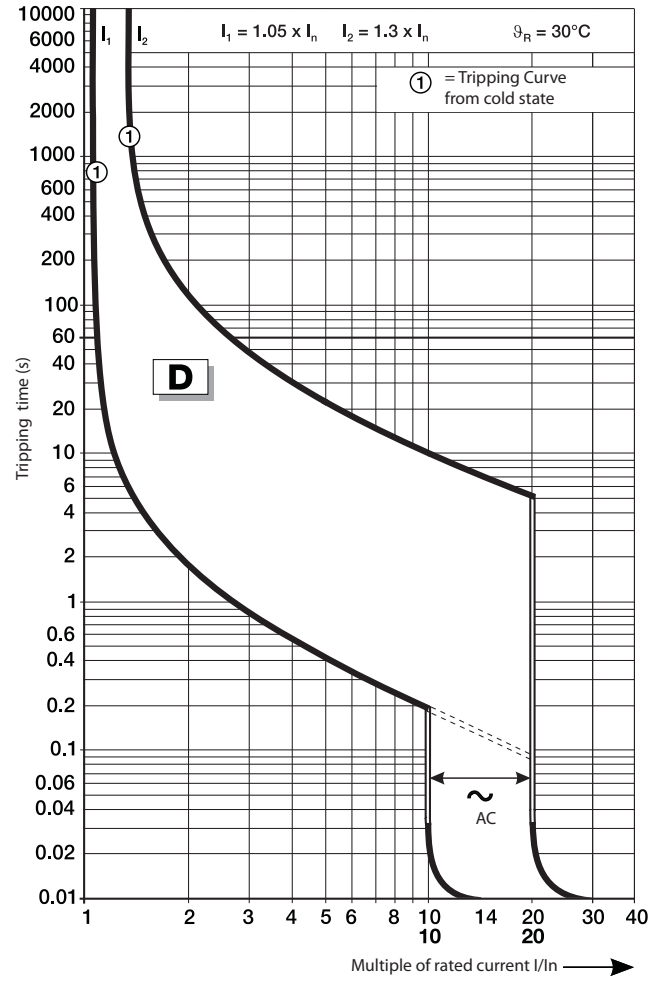



D Curve



Accessories

Right Mount



Photo	Product Description ★‡§	Contacts	Standards	Certifications	UL/CSA Max. Current/Voltage	IEC Ratings Current/Voltage	Cat. No.
	Shunt Trip		UL 489 CSA 22.2 No. 5 EN 60947-5-2	UL Listed CSA Certified CE Marked	110...415V AC 110...250V DC	—	1489-AMST1
			UL 489 CSA 22.2 No. 5 EN 60947-5-2	UL Listed CSA Certified CE Marked	12...60V AC/DC	—	1489-AMST2
	Signal Contact	1 N.O./N.C. (1 C.O.) 	UL 489 CSA 22.2 No. 5 EN 60947-5-1 GB 14048.5	UL Listed CSA Certified CE Marked VDE Certified CCC Certified	1A @ 480V AC 2A @ 277V AC 1.5A @ 125V DC 2A @ 60V DC 4A @ 24V DC	2A @ 230V (AC-14) 1A @ 400V (AC-14) 1.5A @ 110V (DC-12) 1A @ 220V (DC-12) 4A @ 24V (DC-13) 2A @ 60V (DC-13)	1489-AMRS3
	Auxiliary Contact	1 N.O./N.C. (1 C.O.) 	UL 489 CSA 22.2 No. 5 EN 60947-5-1 GB 14048.5	UL Listed CSA Certified CE Marked VDE Certified CCC Certified	1A @ 480V AC 2A @ 277V AC 1.5A @ 125V DC 2A @ 60V DC 4A @ 24V DC	2A @ 230V (AC-14) 1A @ 400V (AC-14) 1.5A @ 110V (DC-12) 1A @ 220V (DC-12) 4A @ 24V (DC-13) 2A @ 60V (DC-13)	1489-AMRA3

★ A maximum of two auxiliary contacts **OR** one signal contact and one auxiliary contact may be installed with or without one shunt trip per 1489-M. If a shunt trip is not used, two signal contacts may be installed per 1489-M.

‡ A maximum of three accessories may be installed per 1489-M. The shunt trip must be mounted closest to the 1489-M, then the signal contact, then the auxiliary contact(s). For allowed combinations, and installation instructions please contact your local Rockwell Automation sales office or Allen-Bradley distributor.

§ The shunt trips are allowed two wires per terminal (one wire per terminal slot). The signal and auxiliary contacts are allowed up to two wires per terminal.

Toggle Mount

Photo	Product Description	Cat. No.
	Lock-out attachment for 1-pole MCB	189-ALOA1
	Lock-out attachment for multi-pole MCB	189-ALOA2

Accessory Approximate Dimensions

Note: Dimensions are shown in millimeters (inches). Dimensions are not intended for manufacturing purposes.

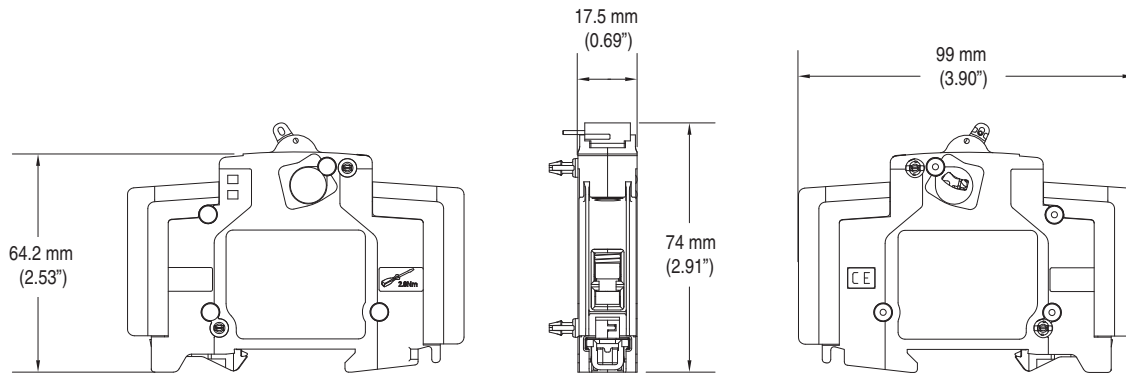

1489-AMST1 and 1489-AMST2

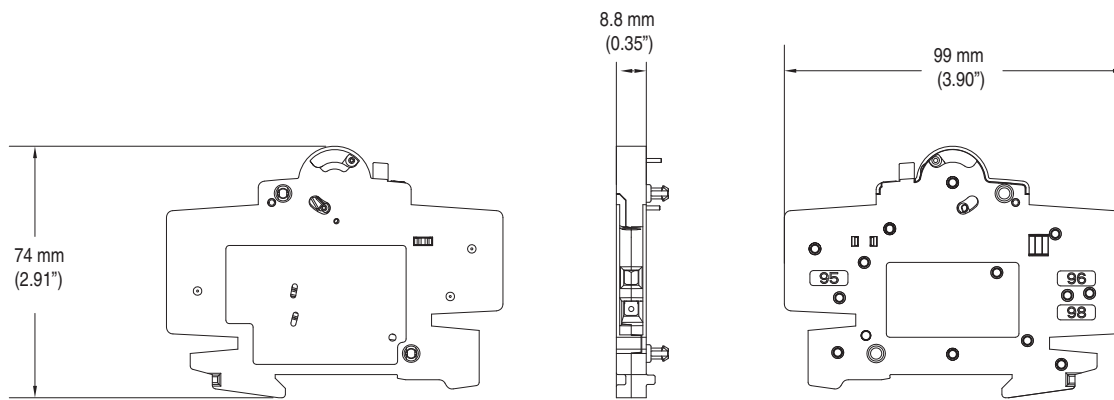

1489-AMRS3

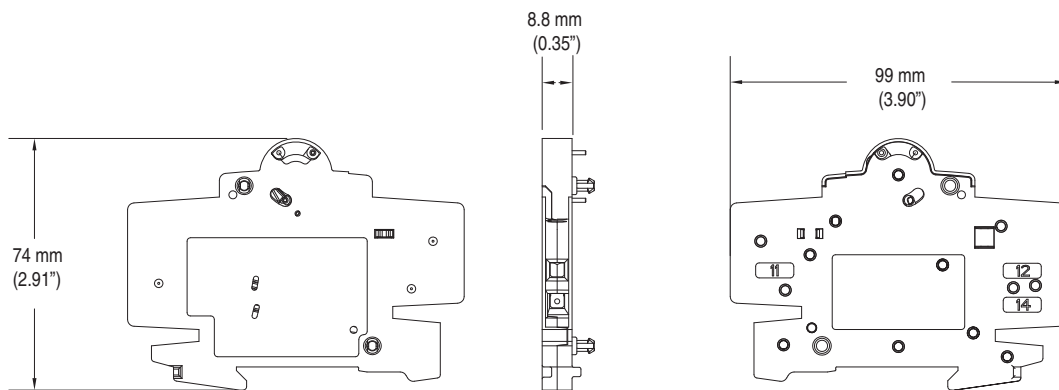

1489-AMRA3

Bus Bars

1489-M Bus Bars

Phase	No. of Pins	No. of Circuit Breakers	Pkg Qty.	Cat. No. ★‡
1-Phase	6	6	10	1489-AMCL106
	12	12	10	1489-AMCL112
	18	18	10	1489-AMCL118
2-Phase	6	3	10	1489-AMCL206
	12	6	10	1489-AMCL212
	18	9	10	1489-AMCL218
3-Phase	6	2	10	1489-AMCL306
	12	4	10	1489-AMCL312
	18	6	10	1489-AMCL318

★ cULus, UL 508, EN 60947-1, CE Marked

‡ Maximum of three bus bars allowed

1489-M Bus Bar Accessories

Description	Pkg. Qty.	Cat. No. ★
Terminal Power Feed, 35 mm ²	10	1489-AMCLT35
Dedicated Power Feed, 50 mm ²	10	1489-AMCLT50D
Protective Shroud (for unused pins)	10	1489-AMCLPS

★ cULus, UL 508, EN 60947-1, CE Marked

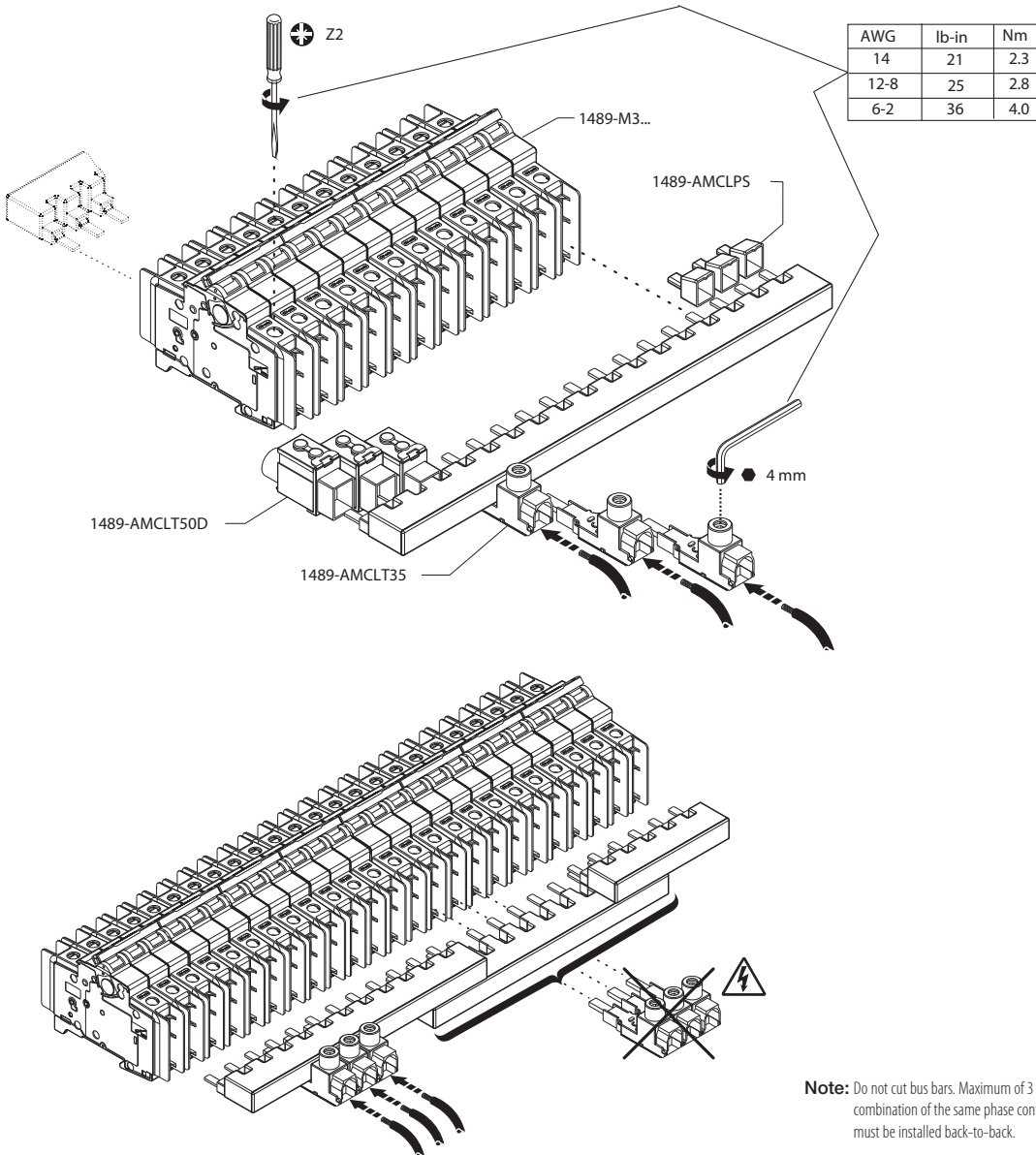

Note: Do not cut bus bars. Maximum of 3 bus bars allowed in any combination of the same phase configuration. Multiple bus bars must be installed back-to-back.

Bus Bar Approximate Dimensions

Note: Dimensions are shown in millimeters (inches). Dimensions are not intended for manufacturing purposes.

1-Phase Bus Bars

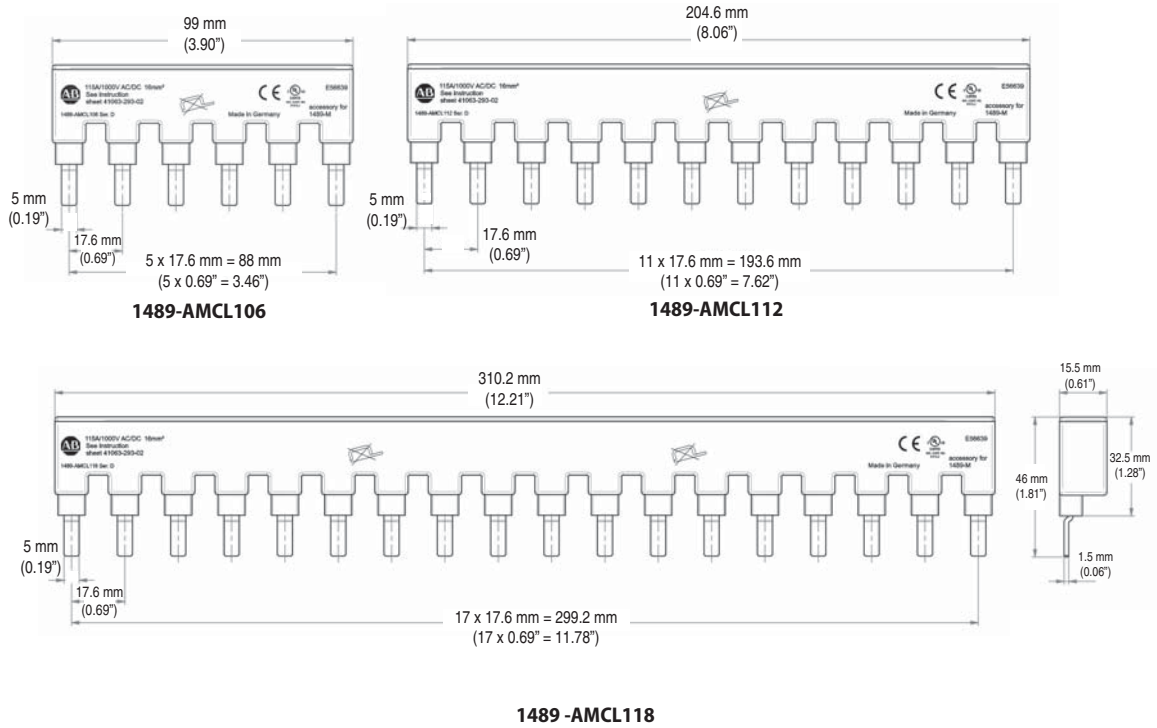

Bus Bar Approximate Dimensions

Note: Dimensions are shown in millimeters (inches). Dimensions are not intended for manufacturing purposes.

2-Phase Bus Bars

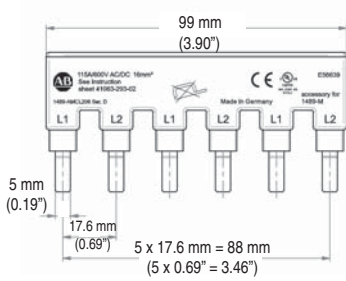

1489-AMCL206

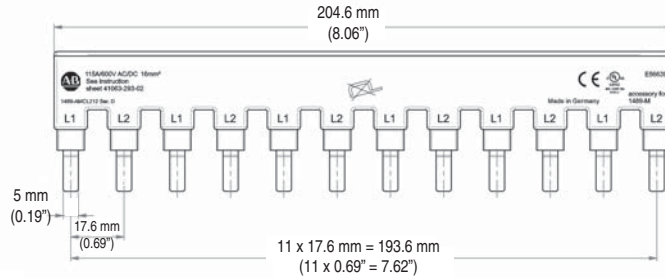

1489-AMCL212

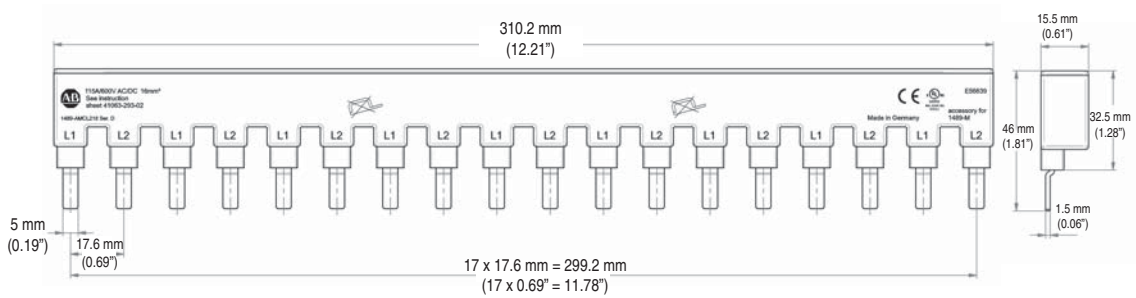

1489-AMCL218

Bus Bar Approximate Dimensions

Note: Dimensions are shown in millimeters (inches). Dimensions are not intended for manufacturing purposes.

3-Phase Bus Bars

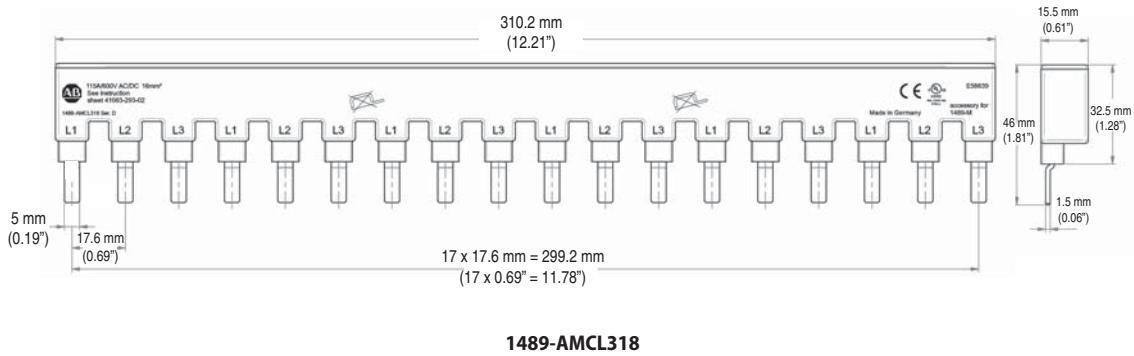
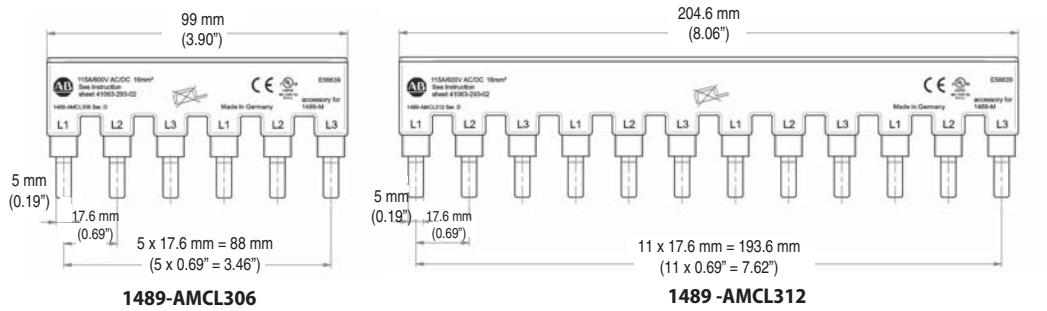

Bus Bar Accessory Approximate Dimensions

Note: Dimensions are shown in millimeters (inches). Dimensions are not intended for manufacturing purposes.

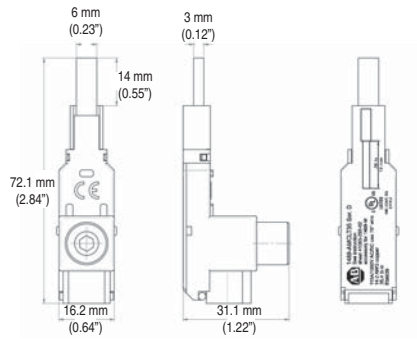

1489-AMCLT35

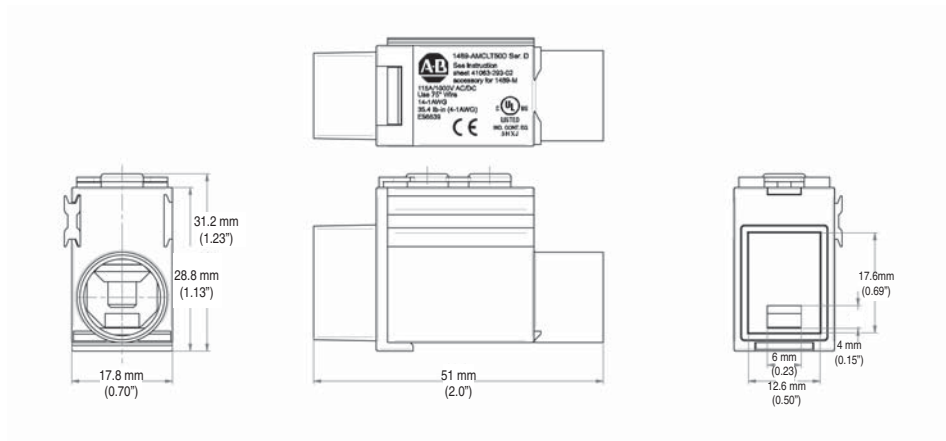

1489-AMCLT50D

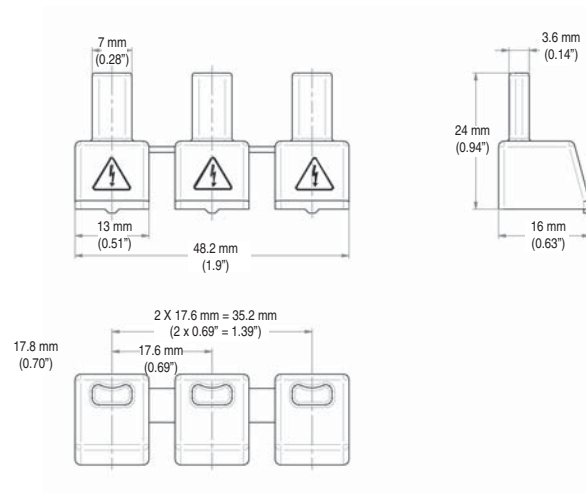

1489-AMCLPS